



Bill Poole, Principal  
Adell Cothorne, Asst. Principal  
13100 Waters Landing Drive  
Germantown, MD 20874  
Phone (301) 353-0915  
Fax (301) 601-0392  
PTA Pres: Denise Ackerman  
denise1165@gmail.com

## From the Principal

### Box Tops for Education

Congratulations to the winners of the Box Tops Summer Contest:

Jordan Beachley (2<sup>nd</sup>)

232 box tops

Jessica Witters (5<sup>th</sup>)

150 box tops

Brendan McMahan (3<sup>rd</sup>)

141 box tops

The total number of Box Tops collected over the summer is 1,735 coupons which is equivalent to \$173.50. Big thanks to all of you who participated. Your support is greatly appreciated.

The winners for the month of September are Matthew Saundry (4<sup>th</sup>) and Chloe Umali (2<sup>nd</sup>). Congratulations to you both! To enter the monthly contest, simply attach 10 Box Tops to the collection sheet and return the completed sheet to school. The winners in October will be announced on the 31<sup>st</sup>. If you have any questions, please call Tess Rikhoff at (301) 528-5372 or email tess0930@hotmail.com .

Sound the Good News!  
The fifth grade chorus has a musical performance for family and friends on Wednesday, October 29, 2008 from 9:30-10:15am at Waters Landing in the All Purpose Room. Please mark your calendars so you can come and enjoy the performance. There will NOT be a nighttime presentation for this performance.  
Sincerely, Kathy Tyndall

Dear WLES Parents and Guardians,

We want to begin this week's letter with an important note about a tremendous resource available to our students, The George B. Thomas, Sr. Learning Academy. Its mission is to accelerate students' mastery of academics, specifically reading, language arts, and mathematics, and to close the achievement gap. Locally, it is held at Northwest High School. The Learning Academy is a tutoring and mentoring program that enhances the academic performance and achievement of students in grades 1 through 12. On Saturday mornings, from 8:30-11:30 a.m., certified teachers and volunteers work with students on core subjects and teach successful learning/studying strategies. This is a low to no-cost program that has greatly benefited many students over the years, including students from Waters Landing. Please consider finding out more about what it has to offer. Registration has begun, but there is not a limit. This Saturday registration begins at 9:45 a.m. at Northwest. For more information, please call Elyse Ridges at (301) 460-2121. You can also call their headquarters at (301) 320-6545 or visit them on the web at [www.gbtlearningacademy.org](http://www.gbtlearningacademy.org).

Next I'd like to thank the volunteers that have been assisting us with our youngest students ( K & 1) during their lunch times from 11:30am-12:30pm. We can always use extra hands, however, so please consider dropping by to assist during these hours if you have time. Just check in at the main office for a Visitor's sticker and join us in the Dining Room. Many of you have noticed how crowded our parking lot is these days. You've been wonderful in following our guidelines for safety in the parking lot, and we are looking forward to the completion of the painting of arrows and new signs. On evenings when there are events which fill our lot, we ask that you not park in the Waterford Place Community directly across the street from the school. Their roads are not county maintained, but privately owned and maintained. So please remember to use our parking spaces and on-the-street parking for school events, drop-off or pick-up. We thank you in advance for your cooperation.

About thirty parents and staff representatives met last Wednesday night to learn more about the grading and reporting policy and to get a look at the new report card that is being piloted in first through third grades. We want to thank Ms. Ebony Langford for her informative presentation to our community. On another note, you should have seen by this time an Interim Progress Report for your child. It is a mid-quarter update on the progress of each student. If you have any questions about your child's Progress Report, please contact his or her teacher directly.

In closing, I'd like to mention that students are not allowed to bring toys ( e.g. "tech deck" skateboards) to school, unless they are directed to by a teacher for a special purpose (such as a class presentation). These items often become a distraction to instruction or a source of frustration if lost. Please remind your children of this expectation. Lastly, mark your calendars for Monday, October 13th, the date of our annual Columbus Day Open House. You are invited to visit and get a snapshot of our school "in action". You'll find more specific information about this day in another section of this week's edition. We wish you a healthy and enjoyable weekend!

Sincerely, Mr. Poole and Mrs. Cothorne

Bi-lingual English/Spanish speakers are needed to help translate for our non-English speaking parents. Volunteers can help with phone calls and with translating materials for the newsletter and other written communication. Volunteers are also needed to help in the office daily from 9:00—10:00 a.m. to help translate for those families who need assistance when dropping their students off in the morning. Please email [volunteer@waterslandingpta.com](mailto:volunteer@waterslandingpta.com) if you can help. Thank you!

## Consider Volunteering

The PTA and the school would like to thank all of those who have signed up this year as a volunteer. However, we still need you! Many opportunities are available for all types of volunteers, and maybe you can help. Some teachers do not have a classroom parent, and could use help planning parties or stuffing Friday folders. You can always volunteer to help another teacher even if you do not have a child in that class. The ESOL homework club needs many volunteers to help students with homework after school. You do not have to speak Spanish or be fluent in English to help. Some teachers could just use help making copies. Please consider helping out if you can. For more information, you can either visit the web site, [www.waterslandingpta.com/volunteer.html](http://www.waterslandingpta.com/volunteer.html), or you can send an email to [volunteer@waterslandingpta.com](mailto:volunteer@waterslandingpta.com). Thank you for your help!

## Volunteer Opportunities

### Read To Me /Talk with Me

RTM/TWM is in urgent need of volunteers to help during the week. If you can volunteer any day from

8:50-9:30am, please contact RTM/TWM Coordinator Janet Williams at

[janet\\_k\\_Williams@yahoo.com](mailto:janet_k_Williams@yahoo.com). Or at 301-528-8663.

The program is also accepting picture book donations and milk crates. If you'd like to make a donation, there is a drop-off box by the main office on the side of the cafeteria.

### Childcare Volunteers

The PTA is in need of volunteers for childcare during the monthly meetings. It's once a month from 7-9pm. If you are interested in helping us out, please call Janet Williams at the above number or email address. Thank you!

## From the President ...

I hope by now that all parents and guardians have taken advantage of at least one of the many ways that the PTA communicates with WLES families. If you haven't joined already, you can sign up for the WLES Listserv at Yahoo Groups. Just send a blank e-mail to [WLES\\_News-subscribe@yahoogroups.com](mailto:WLES_News-subscribe@yahoogroups.com). When you receive a reply e-mail from the group, simply reply back to confirm your subscription and you will begin to receive notices sent out by the PTA regarding upcoming school and PTA events and other news regarding the school. Also be sure to bookmark our web site, [www.waterslandingpta.com](http://www.waterslandingpta.com), for all sorts of information updated on a regular basis: breaking school news, school calendar, menus, staff listing, volunteer opportunities, and our newsletter, just to name a few. The "School Information" page was recently updated with information regarding school policies on things such as early dismissal, student absences, birthday parties, contacting staff, and more. Also, for information on MANY programs and seminars offered in the community on topics such as medical assistance for families, how to register for the magnet school program, or inclusion of students with autism spectrum disorders, please visit our "Community" page, which is updated weekly with new information.

Our next PTA business meeting will be held on Tuesday, October 7 in the Media Center. We will begin at 7:00 with a half hour presentation from Bruce Hansen, our Field Security Coordinator. He will be speaking about the security procedures for our new portable classrooms, including what precautions can be taken when students have to walk to the school to use the restrooms. Please feel free to join us to hear what Bruce has to say, and to ask questions. Our meeting will begin promptly at 7:45, and child care will be provided.

By now everyone should have received a Sally Foster packet, which is our Fall Fundraiser. Please keep in mind that the money raised through this fundraiser, and others throughout the year, will go directly to supporting the four cultural arts day programs which the PTA has scheduled for all students this year, our three Scholastic Book Fairs, the Snowball Dance in December, the Reflections Art Program, and an exciting Science Night in the Spring (just to name a few!). If you are not interested in purchasing anything from Sally Foster, we welcome donations made directly to the WLES PTA. We hope that you will help to make this fundraiser a huge success.

Thank you to everyone who has joined the PTA so far! We are very excited to have many new faces in our membership. It's never too late to join, so sign up now! Have a wonderful October!!

Denise Ackerman

President- Waters Landing PTA

PS—I have a new e-mail address: [denise1165@gmail.com](mailto:denise1165@gmail.com)

## Announcing.....myLunchMoney.com

MyLunchMoney is a new service to make prepayments to your child's cafeteria account using your credit card. The service is easy to use, convenient, private and secure. Simply go to [www.myLunchMoney.com](http://www.myLunchMoney.com) to enroll and start using the site to deposit funds into your child's cafeteria account. Once your account is established, you can check balances and fund the account anytime from your computer. Your child's information is safe and your personal and payment card information is protected by the most advanced Internet security. There is a \$1.95 convenience fee per transaction. Using myLunchMoney.com is optional for families interested in this service. You can still send checks or cash to school, but online payments save time and are convenient.

For more information about how to use this exciting new service, visit [www.myLunchMoney.com](http://www.myLunchMoney.com). In addition, you'll receive an information flyer which can help to answer some of your questions.

## Snack Information from the Cafeteria

In addition to the regular menu items available to students in the cafeteria, please note that snacks and desserts are also being offered for sale for an additional cost to the \$2.40 price of lunch. Since this information is not provided on the menus that are sent home with students, it might be of interest to you to know what is being sold and how much it costs.

Currently snacks are sold only to students in 2nd Grade – 5th Grade, Monday through Thursday (water and juice are sold every day).

If you would like to limit the amount of snacks your child has at school, please contact Debbie Messier, our Cafeteria Manager. You have the option of blocking your child from buying snacks altogether, or you can pick one day of the week when they are allowed to buy a snack or dessert. You can also block their account from being used to purchase snacks, but allow them to pay for a snack with cash on special days. Please contact Debbie to discuss your options further: [deborah\\_a\\_messier@mcpsmd.org](mailto:deborah_a_messier@mcpsmd.org). Be sure to include your child's name and PIN number when requesting changes to their account.

Chips - \$0.65

Apple snack - \$0.25

Large water bottle - \$0.75

Small water bottle - \$0.50

And coming soon, cookies will be sold for \$0.25, and brownies for \$0.50.

Ice Cream - \$0.50-\$1.00

Large Apple Juice/Fruit Punch - \$1.50

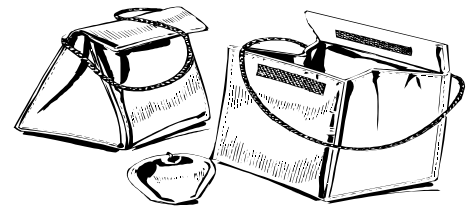

## ESOL Homework Club

Waters Landing is excited to offer an ESOL Homework Club that will run Tuesdays and Thursdays from 3:35pm to 4:20pm starting mid-October. Please consider volunteering in this invaluable program! This free after school activity for 1st—5th graders is important in providing the extra support needed while our second language learners become more proficient in English.

Any amount of time is appreciated, from weekly to monthly. You do not need to speak Spanish or be fluent in English to help out, younger siblings are welcomed. Please fill out the form below and return it to your child's classroom teacher. For further information, please call Mrs. Jafari at 301-353-0915 or email her at [Heather\\_P\\_Jafari@mcpsmd.org](mailto:Heather_P_Jafari@mcpsmd.org)

.....  
 YES, I would be interested in helping out.

The following day(s) work best for me:

Tuesday

Thursday

No, I can't at this time, but may be interested at a later date.

Name \_\_\_\_\_

Phone Number \_\_\_\_\_

Classroom teachers: Please put in Heather Jafari's mailbox.



## Councilor's Corner

### GETTING TO KNOW YOU

We have many new staff members. Our young, budding journalists are interviewing them so that we may get to know one another better.

Thank you to Gabriela Carpio, Ashley Hayes, Eleana Parsons, and Gabriella Umberger for their enthusiasm in undertaking this project and interviewing Ms. Brelsford, our new fourth grade teacher.

Ms. Brelsford:

What do you like best about WLES?

I like the class. We have a great group of learners. I like working with the fourth grade teachers. They are very welcoming to me, nice and caring, and make me feel very comfortable here.

What three words best describe you?

Kind, fair and hard-working.

Do you play sports?

Not right now....but growing up, I played soccer, lacrosse and I ran cross-country.

Do you have any pets?

I have a puppy and it is 6 months old. Its name is Chip.

What is your favorite book?

I would have to say, The Great Kapok Tree. I like it because it is about the rainforest and the animals there, and I like the rainforest.

Are you married? Do you have children?

No, I am not married and I don't have any children.

Where and for how long have you been teaching? Why did you come to WLES?

My first year of teaching was in Rockville, fourth grade.

Then I went to Potomac to teach fourth grade for two years, but there was no longer a position for me to stay there and Mr. Poole offered me a job and I had a great feeling about WLES and I was right!

What do you like to do when you are not working?

I like to visit my family and friends. I go to the movies, shopping, and sports events. I am pretty much open to doing many things.

## Book Fair News!

The Annual Fall PTA Book Fair will be here Monday October 13 - Thursday October 16 from 9:00am - 4:30pm. Family Night will be on Wednesday October 15th from 5pm - 7pm. We are taking a reading Safari. More detailed information will be sent home. We're looking forward to seeing everyone at the Book Fair!



## Halloween Party/Costume

As we did last year, Waters Landing will once again celebrate Halloween on October 31 with classroom parties and a brief parade of costumes. For those students wishing to participate in the costume parade, please make sure to follow these guidelines:

1. Students may not wear costumes to school. They must be able to transport them in a backpack or bag of some kind.
  2. Costumes for our school's recognition of Halloween should not require a change of clothing. Please make sure that they can fit over the clothes worn to school or incorporate appropriate clothing, such as a black t-shirt that transitions well into a black cat costume. We find it extremely hard to safely monitor bathrooms appropriately when wholesale changes of clothing are needed.
  3. Costumes should not require make-up. In order to conduct our parade and parties in the allotted time it is imperative that the costume change be quick and easy. Please save the make-up for your neighborhood outings.
  4. Costumes must provide for maximum safety by avoiding masks that seriously restrict a student's field of vision. In addition, any costumes that reach the floor represent a tripping hazard, particularly for students traveling up and down stairs. Costumes may not drag the floor.
  5. Costumes of a violent or gory nature are prohibited for our school celebration. Parents, please be conservative in your selection of costumes that will be worn at school that afternoon, and err on the side of caution. Our goal is to foster fun, not instill fear, especially in our younger students.
  6. There are to be no props that can in any way be construed or interpreted as a weapon.
- As Halloween approaches, you can expect to hear from individual teams regarding the specifics of the classroom celebrations and how you can partner with the team to make this an enjoyable experience for our students. We will also share the plans we have for those students whose families prefer they not participate in the Halloween parties.

## Request from the School Nurse

The school nurse is requesting donations of new small-sized underpants (sizes 4-8) for both boys and girls to have on hand in the health room. Please send in donations to the attention of Beth Glad. Thank you.



## How are your Sally Foster Sales???

We are in full swing of our Sally Foster fundraiser. Our goal is to raise \$9,000 ~ and we know we can meet that!

If you need extra order forms, please e-mail [jrschrock@verizon.net](mailto:jrschrock@verizon.net) with your child's name and teacher and she will backpack one home.

Remember, internet orders can be placed anytime... a great way for out of town relatives and friends to support Waters Landing. We can't wait to start tallying!! Don't forget to add your 6% sales tax to your order! Thank you for supporting your school!

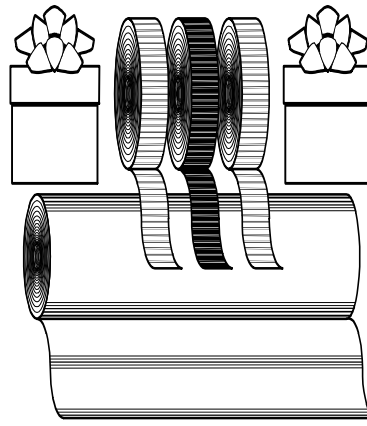

## Happy Birthday!

Stacey Auth 10-7  
Sara Poska 10-10  
Nancy Novak 10-11  
Beth Glad 10-15  
Carrie Staub 10-22  
Jet Merritt 10-23  
Diane Howard 10-30  
Grace Vanech 10-30

## News from the Media Center

The Black-Eyed Susan Book Award honors outstanding books chosen annually by Maryland students. Each year since 1992, the Black-Eyed Susan Book Award has been given to one book in each of several grade-level categories. Students in grades K-5 will have an opportunity to vote for their favorite picture book. Older students may also choose to read one of the chapter books and vote for their favorite chapter book as well.

This year all students will hear the picture books read to them by Mrs. Zygmunt on a video or in media class. Students choosing to read chapter books will read the books on their own. Students reading chapter books must read at least three of the books in order to vote. All voting will take place in April of 2009.

Books can be checked out of WLES library. Many more copies of each book can be found at your local public library. Here is the list of books for this year's Black-Eyed Susan Contest!

### Picture Book

- Barretta, Gene - Now & Ben : the Modern Inventions of Benjamin Franklin
- Bruel, Nick - Who is Melvin Bubble?
- Bruel, Robert O. - Bob and Otto
- Clements, Andrew - Dogku
- Deedy, Carmen Agra - Martina the Beautiful Cockroach: a Cuban Folktale
- Ehrhardt, Karen - This Jazz Man
- Flaherty, Alice - The Luck of the Loch Ness Monster : a Tale of Picky Eating
- Freymann, Saxton... et al. - Knock, Knock!
- Harrington, Janice N. - The Chicken-Chasing Queen of Lamar County
- Kay, Verla - Rough, Tough Charley
- Madison, Alan - Velma Gratch & the Way Cool Butterfly
- Michelson, Richard - Across the Alley
- Sierra, Judy - Mind Your Manners, B.B. Wolf
- Watt, Melanie - Scaredy Squirrel
- Woodruff, Elvira - Small Beauties : the Journey of Darcy Heart O'Hara  
Grades 4-6
- Berlin, Eric - Puzzling World of Winston Breen, The
- Clements, Andrew - No Talking
- Dahlberg, Maurine - Story of Jonas, The
- DeFelice, Cynthia - Ghost of Poplar Point, The
- Graff, Lisa - Thing about Georgie, The: a novel
- Hahn, Mary Downing - Witch Catcher
- Hicks, Betty - Out of Order
- McKissack, Patricia - Friendship for Today, A
- O'Connor, Barbara - How to Steal a Dog
- Pitchford, Dean - Big One-Oh





Official Waters Landing Elementary School PTA  
Membership Form for 2008-2009  
Formulario de Membresia para 2009-2009

Please complete the form below, including the membership dues, and return in an envelop marked PTA to school with your child. Cash or checks welcomed. Please make checks payable to WLES PTA. We encourage donations through the membership process, as well as multiple members per family. Please print legibly, thank you and welcome.

Mother's Name \_\_\_\_\_

Father's Name \_\_\_\_\_

Additional Member's Names \_\_\_\_\_

Total Members \_\_\_\_\_ x \$7.00/each=\$ \_\_\_\_\_

Donation \$ \_\_\_\_\_

Total \$ \_\_\_\_\_

Contact Information

Address \_\_\_\_\_

City \_\_\_\_\_ State \_\_\_\_\_ Zip \_\_\_\_\_

Child's Name \_\_\_\_\_ Child's Teacher \_\_\_\_\_

Open House - October 13, 2008

Monday, October 13 will be Parent Open House at Waters Landing, from 9:30 a.m. - 12:30 p.m.

This is an opportunity for families to see their children in action at school. Feel free to visit throughout the day, but please limit the time of your stay. Extended stays in classrooms can cause undue distractions for other students. Family visits should last for no longer than an hour per child, not including a stay for lunch. Please be aware that the lunch room is filled to capacity this year, so there is limited space for adult visitors who plan to stay and each lunch with their children. Families are encouraged to check with your child or teacher about their schedule for Monday, as some classes will have Art, Music, and/or Physical Education. You are welcome to visit your child in either their homeroom or in one of the Fine Arts classrooms. Please sign in at the registration table in the hallway and pick up your visitor's sticker on the 13th, then enjoy your visit. We look forward to a strong turn-out for our Open House!

**IMPORTANT INFORMATION FOR THIRD GRADE PARENTS**

All third grade students are eligible to apply for the MCPS Highly Gifted Centers.

Applicant Characteristics: Ask yourself: To an exceptional degree, does your child:

1. Show curiosity about ideas, events, and how things work or have a questioning attitude?
2. Demonstrate initiative and intellectual curiosity?
3. Have an ability to learn at a faster rate?
4. Have strong critical and creative thinking abilities?
5. Show empathy and sensitivity towards others?
6. Have an ability to see relationships and detect patterns?
7. Have a positive self-concept?
8. Understand his or her strengths and know when and how to ask for help?
9. Prefer long- range goals to short-term or immediate needs?

These centers are designed for students who learn at a faster pace, can handle advanced concepts of greater complexity, and whose needs cannot be easily met through local GT programming.

The instructional atmosphere promotes thinking skills and instructional strategies that encourage intellectual growth, risk taking and creative expression. Seven centers throughout the county each serve certain geographic areas.

This program is highly competitive. About 2000 applicants apply for only 450 seats.

Timelines:

September- Highly Gifted Center (HGC) applications are mailed to all Grade 3 students.

October 15- HGC evening meeting at Quince Orchard H.S.

November 14- Deadline for applications. HGC applications must be mailed/delivered to the DCCAPS Office

December 15- HGC folders from elementary schools due to DCCAPS office.

For information on HGC: Contact Betty Shevitz at 301-592-2063

## Artist in Residence at Waters Landing

There is exciting news in the Art Department! The Maryland State Arts Council has approved a grant for our school to engage an artist in residence. She will work with a group of our students to design an art installation that will be part of our 20th anniversary celebration. The artist, Tara Holl, is very accomplished and came highly recommended from other MCPS schools with whom she has worked. It has been decided that the group she will work with will be the fifth graders. We want the installation to be a representation of the thousands of students who have passed through our school during the past 20 years. Though its appearance and location is yet to be determined, it will probably be along the lines of each student involved creating a small piece of art that will be assembled by Tara into a larger piece. We would like the input of the entire school community in the form of your response to this question:

"What do you think of when you think of Waters Landing?"

You can e-mail your responses back to WLES art teacher Peter Plant at [Peter\\_M\\_Plant@mcpsmd.org](mailto:Peter_M_Plant@mcpsmd.org). Your timely response to this is appreciated as Tara is scheduled to begin work in October.

## Adult Drum Club Now Forming

For the second year Waters Landing will have an Adult Drum Club! Participants will play various African percussion instruments under the direction of our music teachers Kathy Tyndall and Carrie Staub. Monthly practices will be held on the following dates from 6:00-7:00 p.m. in the Music Room:

October 13

November 10

December 8

January 12

February 9

March 9

The Drum Club Concert will be held on April 2 at 2:00 for the students, and 7:00 for families. Adults do not have to have a child at Waters landing to participate in the Drum Club -- they can be friends of another WLES parent, or adult family members. Child care will be available in the room next door during practices. Please contact Kathy Tyndall if you are interested in joining - [Kathy\\_L\\_Tyndall@mcpsmd.org](mailto:Kathy_L_Tyndall@mcpsmd.org).



## EXTRA! EXTRA! READ ALL ABOUT IT!!!

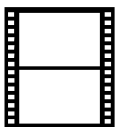

"WOW..."



2009 Reflections Art Program Theme:



Get ready to "WOW"! The PTA says "WOW" to the 2008-2009 Reflections Art Program. Did you know that students who participate in the arts do better in school, and the PTA Reflections Program gives students an opportunity to receive recognition for their artistic endeavors. Encourage your child to create an original work of art based on the 2008-2009 Reflections Program theme, "WOW". There are six arts categories to choose from: Visual Arts, Film Production, Dance Choreography, Musical Composition, Photography and Literature. Check your child's Friday Folder for entry information, rules, and submission deadlines. Then look for the Red Submissions box in the main office. Reflections Program awards are given at the local, county, district, state and national levels. A recognition reception for participants will be in held in December



**Waters Landing**  
ELEMENTARY SCHOOL

# October 2008

Sun	Mon	Tue	Wed	Thu	Fri	Sat
			1 Student Pictures	2	3	4
5	6	7 PTA Meeting 7pm Media Center	8	9 <u>No School</u> Holiday	10	11
12	13 <b>BOOK</b> Open House 9:30am-12:30pm	14 <b>FAIR</b> Market Day Orders Due by 12pm	15 <b>9AM-4:30PM</b> Book Fair Family Night 5-7pm	16 <b>4:30PM</b>	17 <u>No School</u> MTSA Convention	18
19	20	21 Market Day Pick Up 7:30pm	22	23	24 MoCo Community Service Day	25
26	27	28	29	30	31 1st Marking Period Ends Halloween Class Celebrations/Parade	<u>NOVEMBER</u> 3 - No School 4 - No School 5 - PTA Mtg